

Session 504: Engaging residents in capital renewal strategies



Roy Turner

Director, Design and Engineering, Facilities Management
Toronto Community Housing

Steve Jacques

Director, Resident and Community Services
Toronto Community Housing



Toronto Community Housing



Overview

- What is ReSet?
- Healthy Communities Framework
- Resident engagement strategies and plan
- Where are we now?
- Questions

Toronto Community Housing



Challenges

Buildings challenges



Human challenges



Toronto Community Housing 

ReSet: A capital delivery strategy

- Multiple projects at one site at one time:
 - replacing and repairing multiple building components (roofs, boilers, windows, site work, in-suite repairs)
- “One constructor” to manage the work effectively
- Avoids repeat visits and years of disruption
- Builds on learnings from Revitalization program

Toronto Community Housing 

Which communities go first?

A series of indices:

1. Facility condition (FCI)
2. Site planning
3. Building design
4. Community/neighbourhood integration
5. Security
6. Vulnerability
7. Community readiness assessment

Toronto Community Housing



Healthy Community Framework

- Examining the building, site and community relationships as a framework of building standards to provide quality homes while improving community safety and security.
 - What works, what doesn't?
 - What's missing?
 - How is this used?

Toronto Community Housing



Site design: amenity and support

Existing
Single garbage location - not well located for resident convenience.

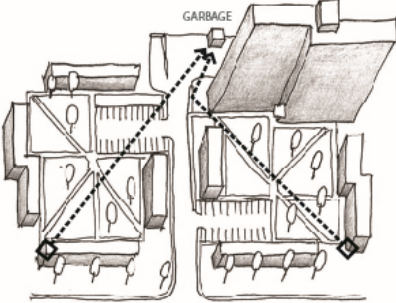

ReSet Strategy
Introduce second garbage location to provide better resident convenience and service.

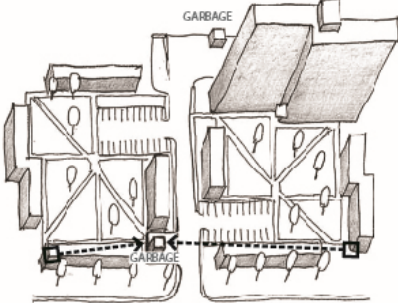

Toolkit Initiatives

- add new garbage bin and associated driveway area

Kit of Parts

- heavy duty asphalt
- bin enclosure

Toronto Community Housing 

Site design: quality of place

Existing
Ground level consumed with dark, unsafe parking, with second level deck used unsuccessfully for private outdoor resident space, instead of grade.



ReSet Strategy
Replace, as a major but essential strategy, the existing parking and deck cover with grade level, open parking and a new street, walkways and front yards. Make required adjustments to residential layouts to accommodate ground level changes.

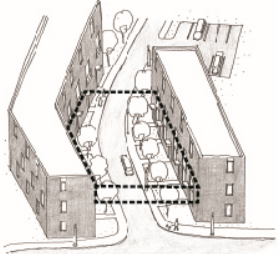

Toolkit Initiatives

- create a new, normal street condition with properly defined yards, streetscape landscaping and street addresses to homes

Kit of Parts

- major demolition equipment
- bricks and mortar
- windows and doors
- asphalt
- concrete sidewalks
- lighting
- trees and landscaping

Toronto Community Housing 

Building design: amenity and support

Existing
Minimal lobby - unwelcoming and poorly organized mail and resident communications.



ReSet Strategy
Create a welcoming and amenable sequence of entry spaces.

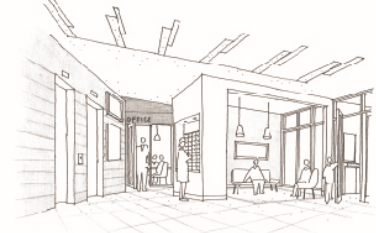

Toolkit Initiatives

- open lobby to the outside and add new seating area and artwork
- create a concierge/office space off lobby for better supervision
- introduce new lobby lighting, materials and colour
- construct separate alcove for mail
- organize resident communications with video monitor and single bulletin board

Kit of Parts

- drywall
- windows
- interior glazed screen
- porcelain wall and flooring tiles
- new lighting
- video monitor
- bulletin board
- artwork



Building design: building identity

Existing
Unwelcoming, non-descript building entrance.



ReSet Strategy
Open up ground floor and create attractive and inviting building entrance.



Toolkit Initiatives

- add new canopy with signage and lighting
- renovate lobby area and add new common building uses, such as meeting room or craft room, with views to the outside
- redo entrance landscaping to create clear and distinctive entrance from the sidewalk and roadway

Kit of Parts

- canopy
- windows
- drywall
- new lighting
- lobby seating
- unit pavers
- landscaping
- flower pots



Resident engagement: desired outcomes

Residents are the key:

- Build resident capacity and leadership
- Support resident participation
- Develop/identify opportunities for resident involvement



Toronto Community Housing



Resident engagement: principles



- Residents are the key
- No two communities are alike
- Local engagement plans are adaptable/flexible
- Responsive to community strengths challenges

Toronto Community Housing



Engagement plan components

- Identify community leaders
- Resident-led asset mapping
- Resident/TCHC planning committee
- Resident/Consultant Selection Committee
- Resident/Consultant Design Committee
- Workshops, forums, community meetings, visioning session, focus groups, surveys

Toronto Community Housing



Consideration for success

- Improving community safety
- Addressing stigmas
- Improving public spaces and community facilities/amenities
- Building resident capacity to source services
- Creating economic and social development
- Building bridges with surrounding neighbourhood
- Engaging local service agencies

Toronto Community Housing



Where are we now?

- Steering committee established
- Community announcements
- Door knocking and lobby
- Resident leaders selected their consultant
- Public announcement with Mayor John Tory and resident leaders



Toronto Community Housing



Discussion

Questions?

Toronto Community Housing



16

Thank you!

Roy Turner
roy.turner@torontohousing.ca

Steve Jacques
steve.jacques@torontohousing.ca

Toronto Community Housing

